



SAN PEDRO CREEK

Improvements Project

Construction and Design Update

Project Phases

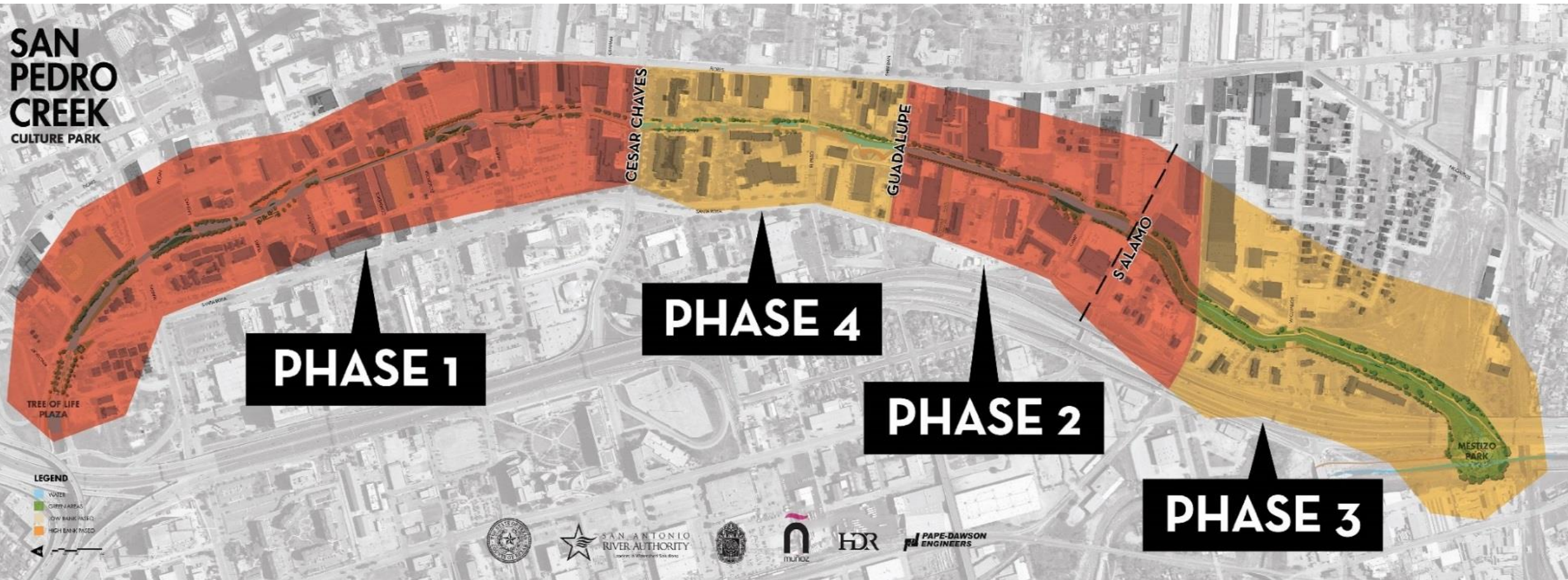

Phase 1 Limits

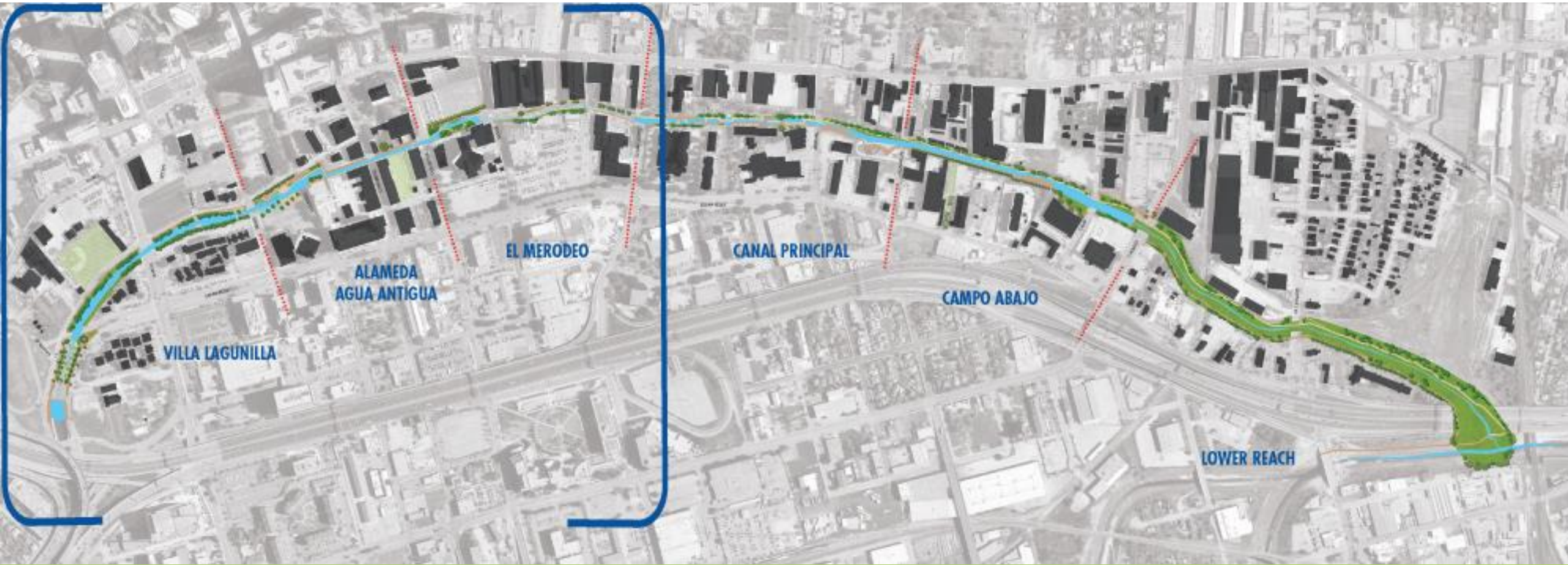

Dolorosa Action Plan

- Tunnel Inlet to Dolorosa Street
 - Excludes Dolorosa Street bridge
- Schedule showing final completion to Dolorosa by April 27, 2018
- Deliverables by SARA
 - USACE Permit
 - Design Deliverables (Work Packages)
 - ROW (Temporary Construction Easements)
 - Utility Relocations

USACE Permit

- Initial USACE projected permit issuance late 2017
 - Permit required December 23, 2016
- Aggressive communication and coordination with USACE
 - Frequent trips to Fort Worth
- Determination of 408 & permit limits
- Expedited Reviews
 - 404 regional permit
 - Section 106 review – Historical Structures
- Current projected issuance January 3, 2017

Work Packages

- Work Package 1 - Utility Bores
 - Construction Start December 2016
- Work Package 2 - Heavy Civil & Utility Work – Inlet to Houston St.
- Work Package 3 - Foundation Underpinning
 - Packages 2 & 3 construction start January 2017

Work Packages

Work Package	Design Milestone	Bidding Milestone	Start of Construction
WP 4 - Utilities & Demolition from Houston to Dolorosa	10/04/16	11/30/16	02/01/17
WP 5 - Structural Elements from Houston to Commerce	10/31/16	12/28/16	03/02/17
WP 6 – Drilled Shafts (Walls/Ped Bridges) Commerce to Dolorosa	11/28/16	01/25/17	03/22/17
WP 7 - CPS Gas & CPS Electric	12/13/16	02/09/17	04/01/17
WP 8 - Remaining Scope from Houston to Commerce	12/13/16	02/09/17	04/01/17
WP 9 - Remaining Scope from Commerce to Dolorosa	02/28/17	04/28/17	06/25/17
WP 10 - Landscaping, Irrigation, Wayfinding	02/28/17	04/28/17	06/25/17



Deliverables: Right of Way

- Acquisitions nearly complete
 - One parcel remaining
- Temporary Construction Easements (TCEs)
- COSA TCE
 - Multi-step approval process
 - City Council approval in November
 - Includes property for construction staging
- Private Landowners
 - Coordination ongoing

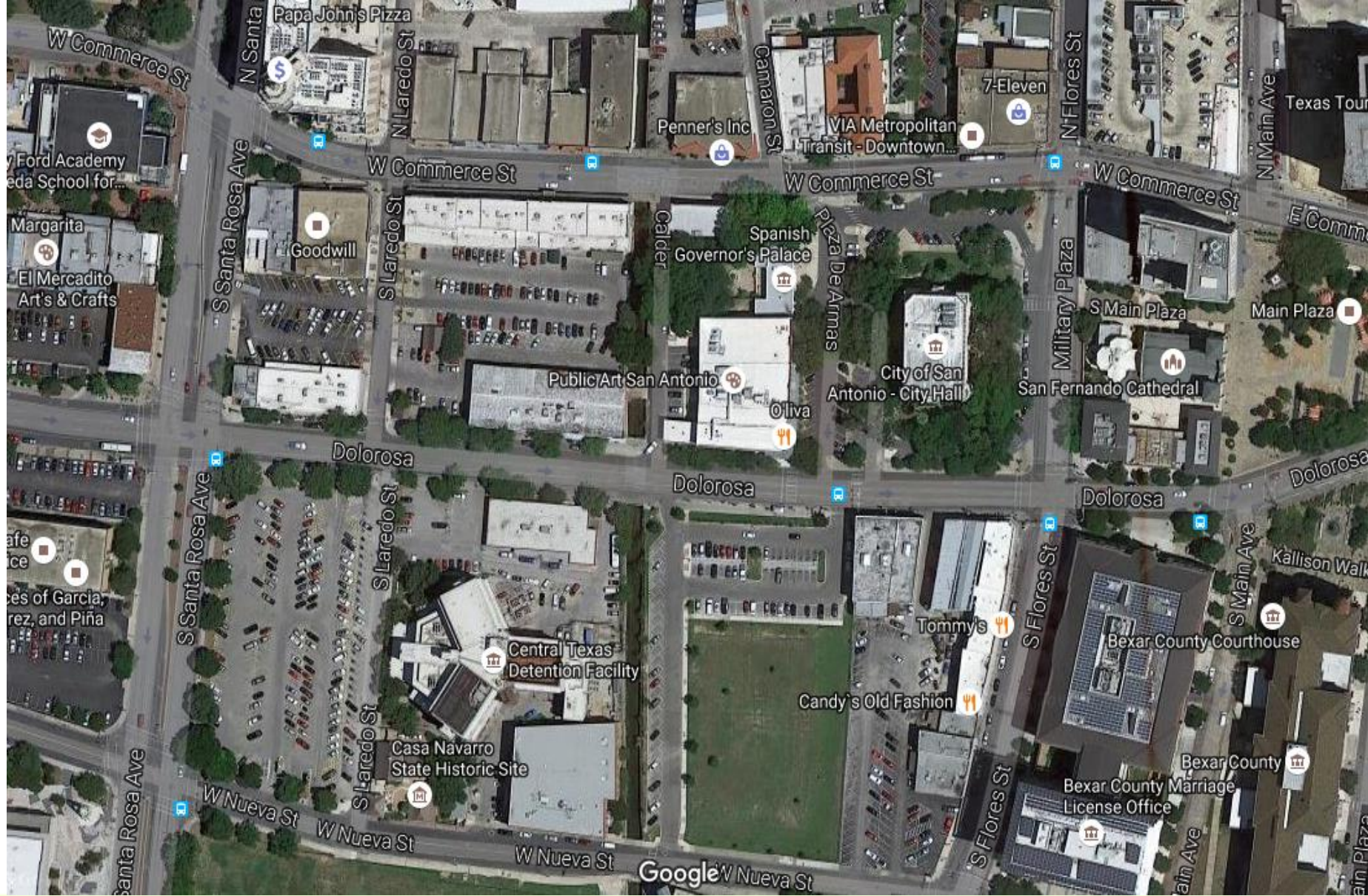

Utility Relocations

- Existing Utilities in Conflict
 - Spectrum (formerly Time Warner), AT&T, Grande, AT&T Metro, Level 3, Bexar County, COSA
 - SAWS, CPS
- Coordination ongoing
 - Schedule integration
 - Deliverable dates

Existing Utilities



Joint Telecom Bore (HDD)

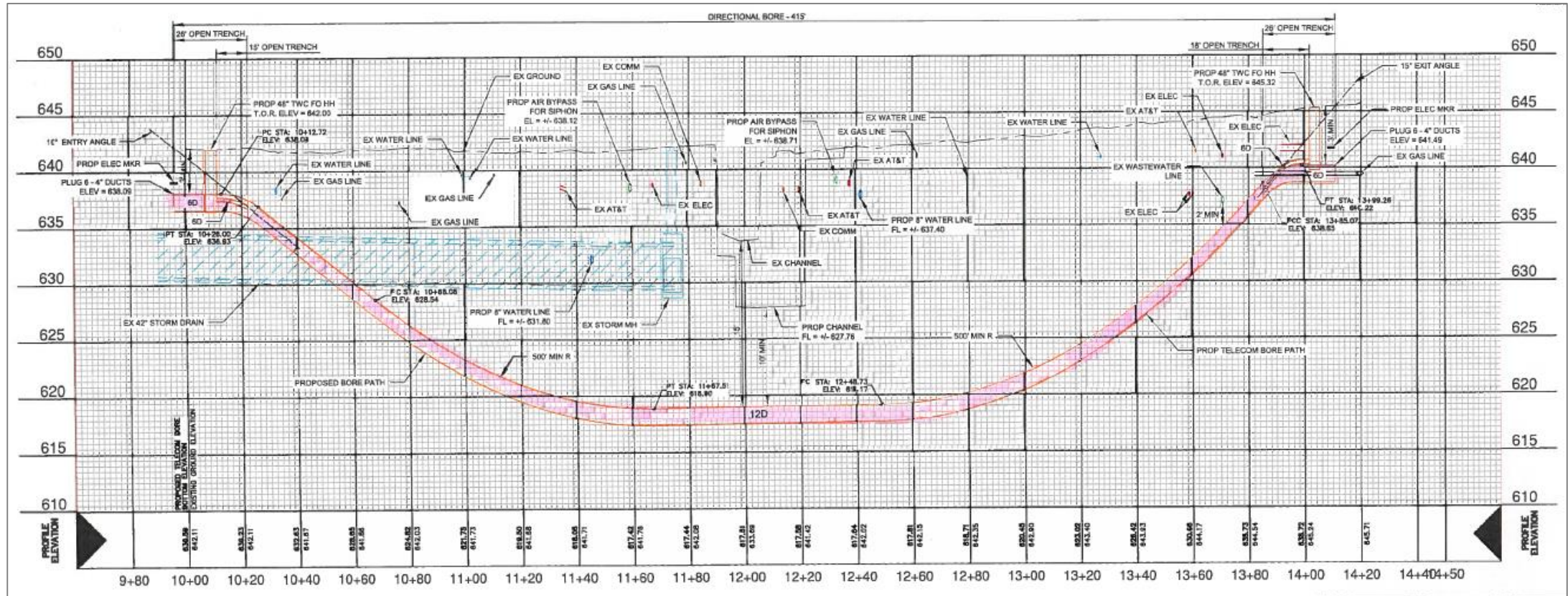

Bridge Work Packages

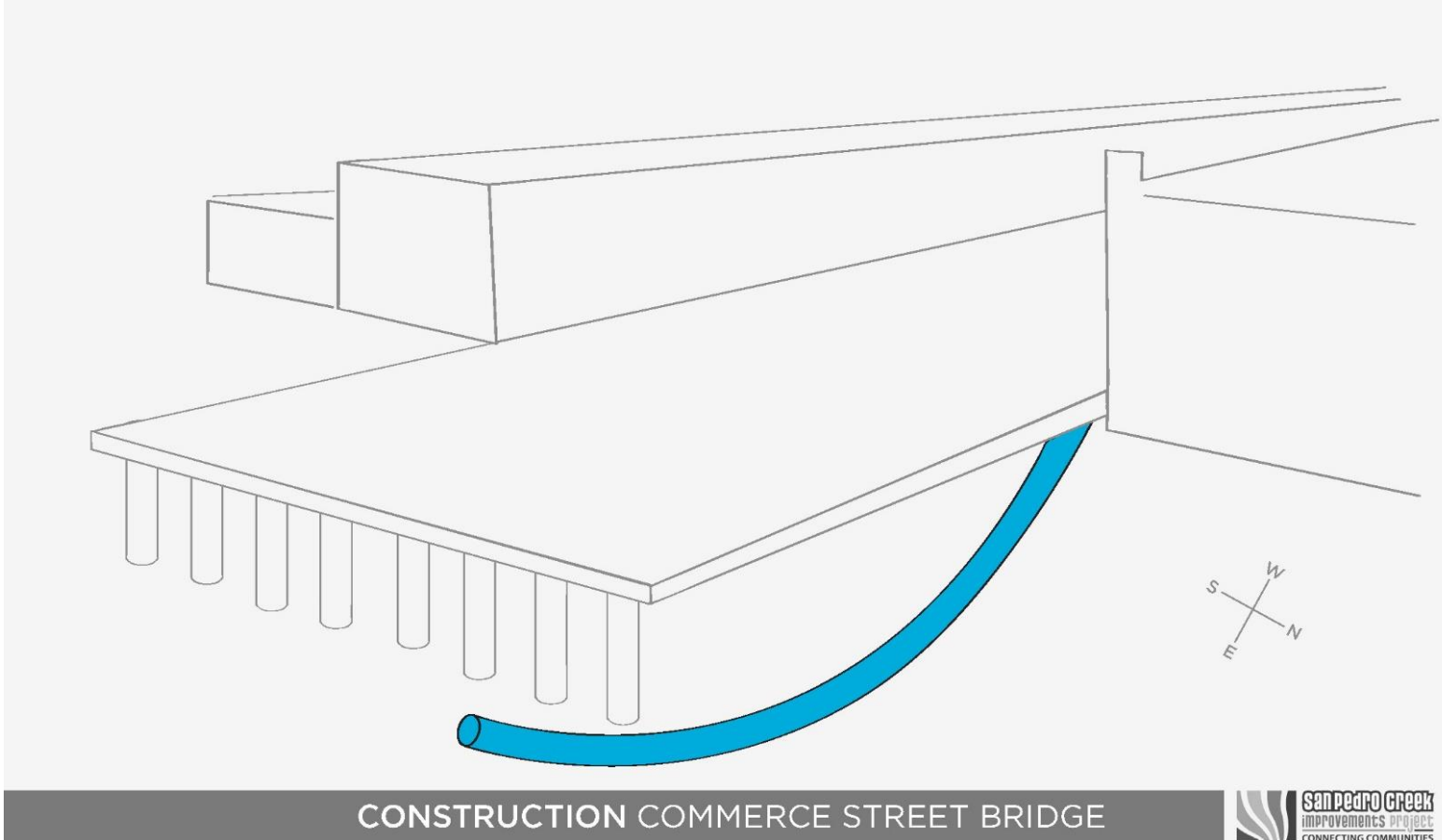

HDD
Joint Bore



San Pedro Creek
improvements project
CONNECTING COMMUNITIES
WWW.SPCPROJECT.ORG

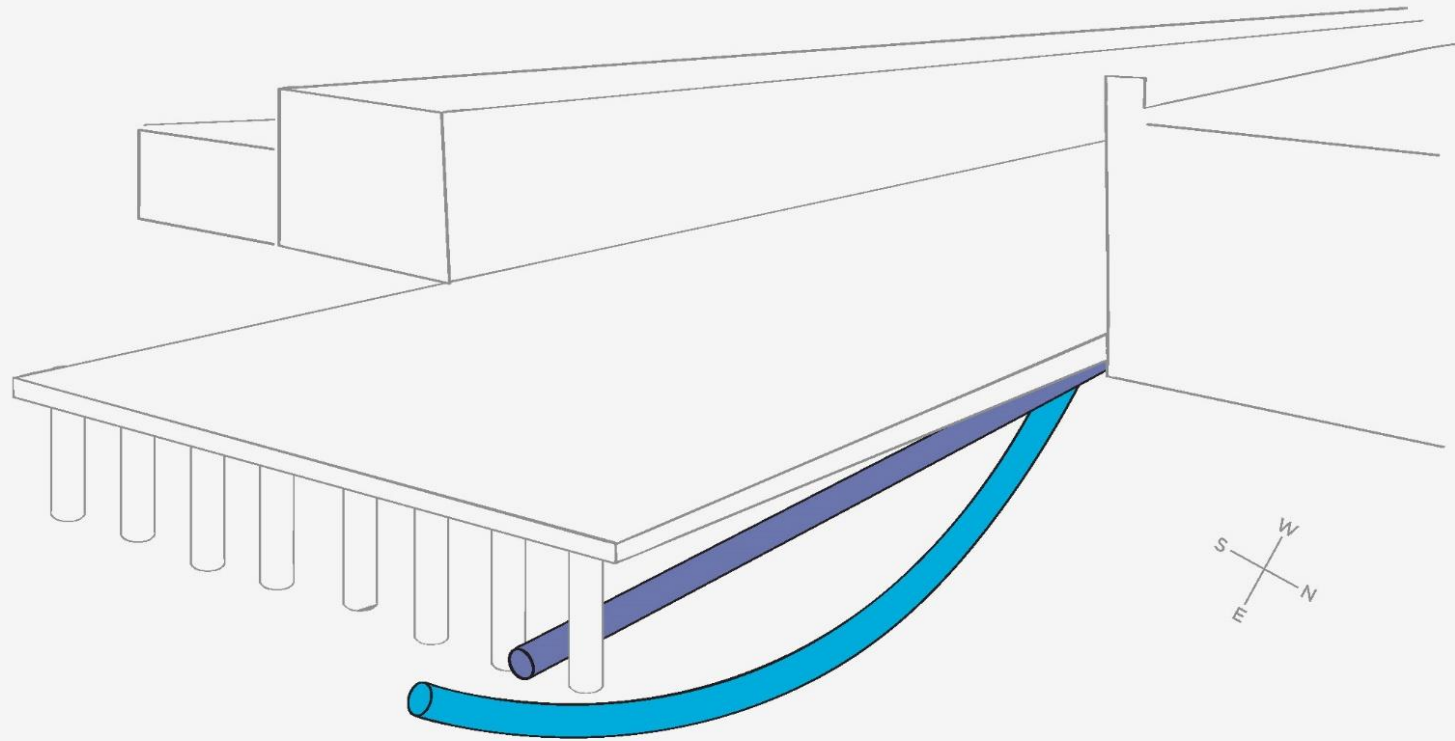

CONSTRUCTION COMMERCE STREET BRIDGE



HDD
Joint Bore



SAWS Utilities
utilities &
bridge demo



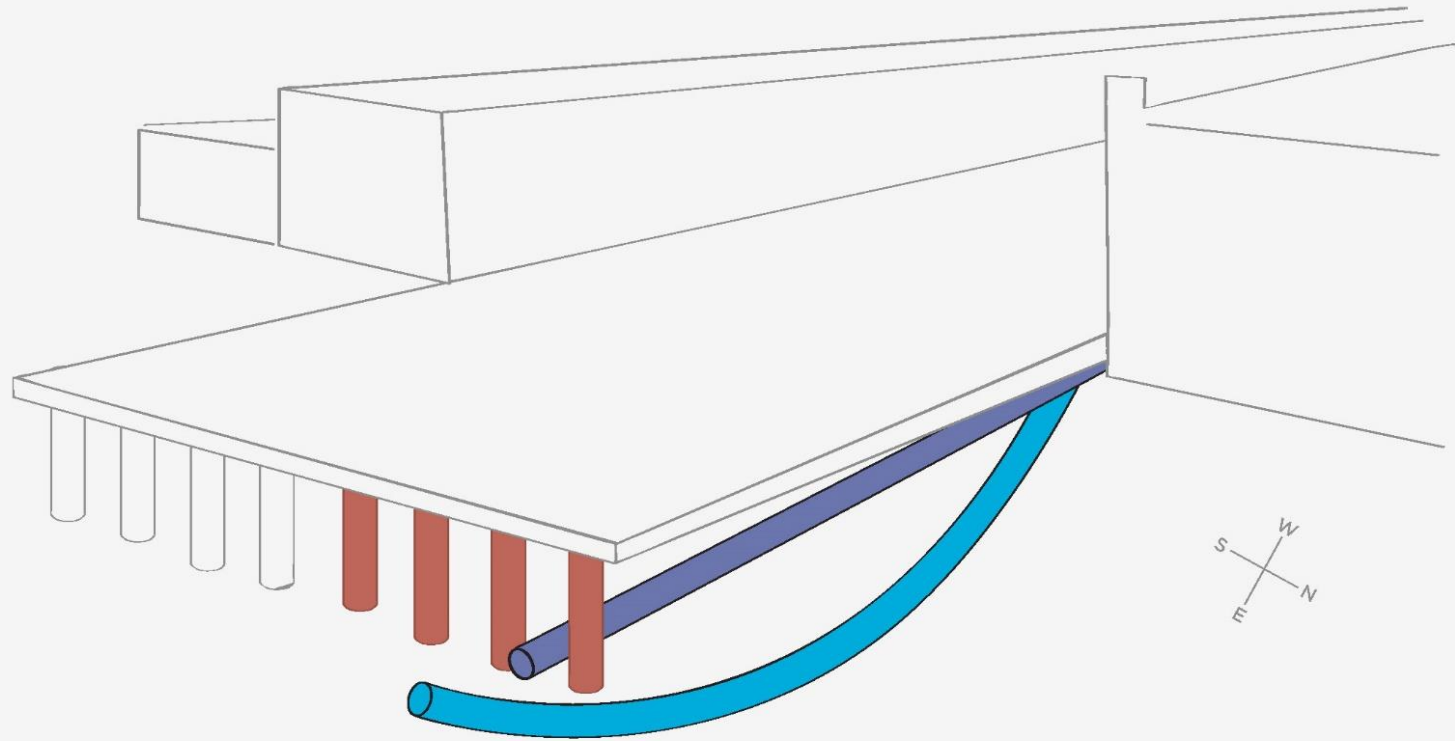

CONSTRUCTION COMMERCE STREET BRIDGE



**HDD
Joint Bore**



SAWS Utilities
utilities &
bridge demo



Shafts
structural supports



**San Pedro Creek
improvements Project**
CONNECTING COMMUNITIES
WWW.SPCPROJECT.ORG

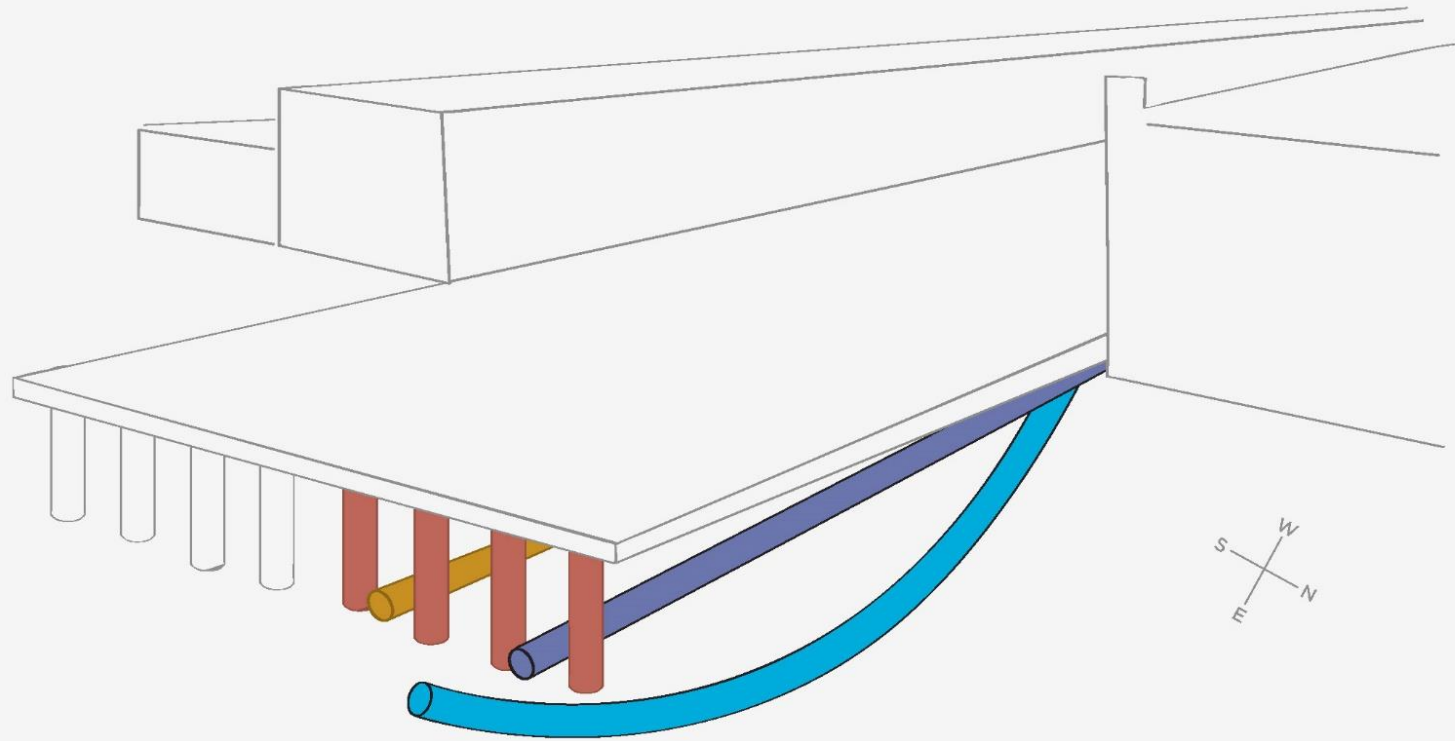

CONSTRUCTION COMMERCE STREET BRIDGE



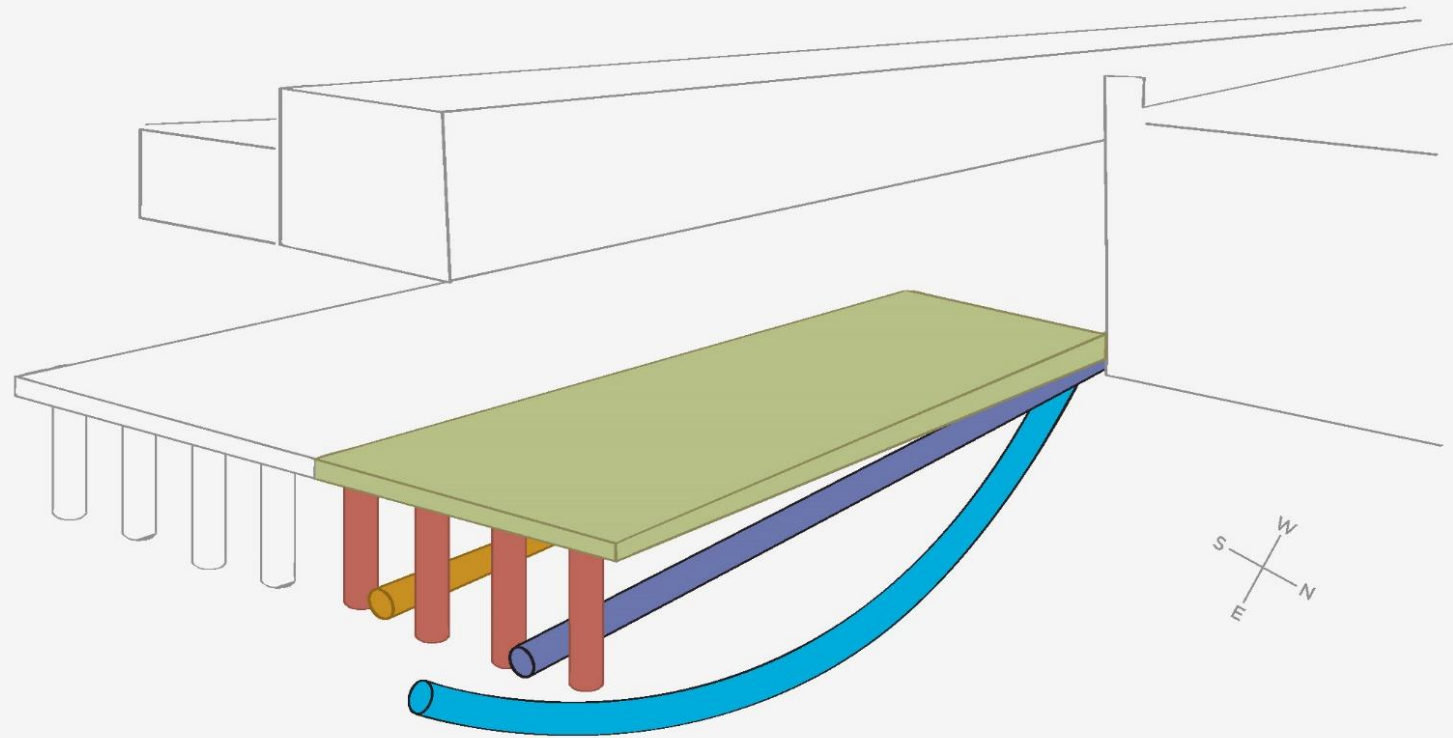

CONSTRUCTION COMMERCE STREET BRIDGE



Creek Work Packages

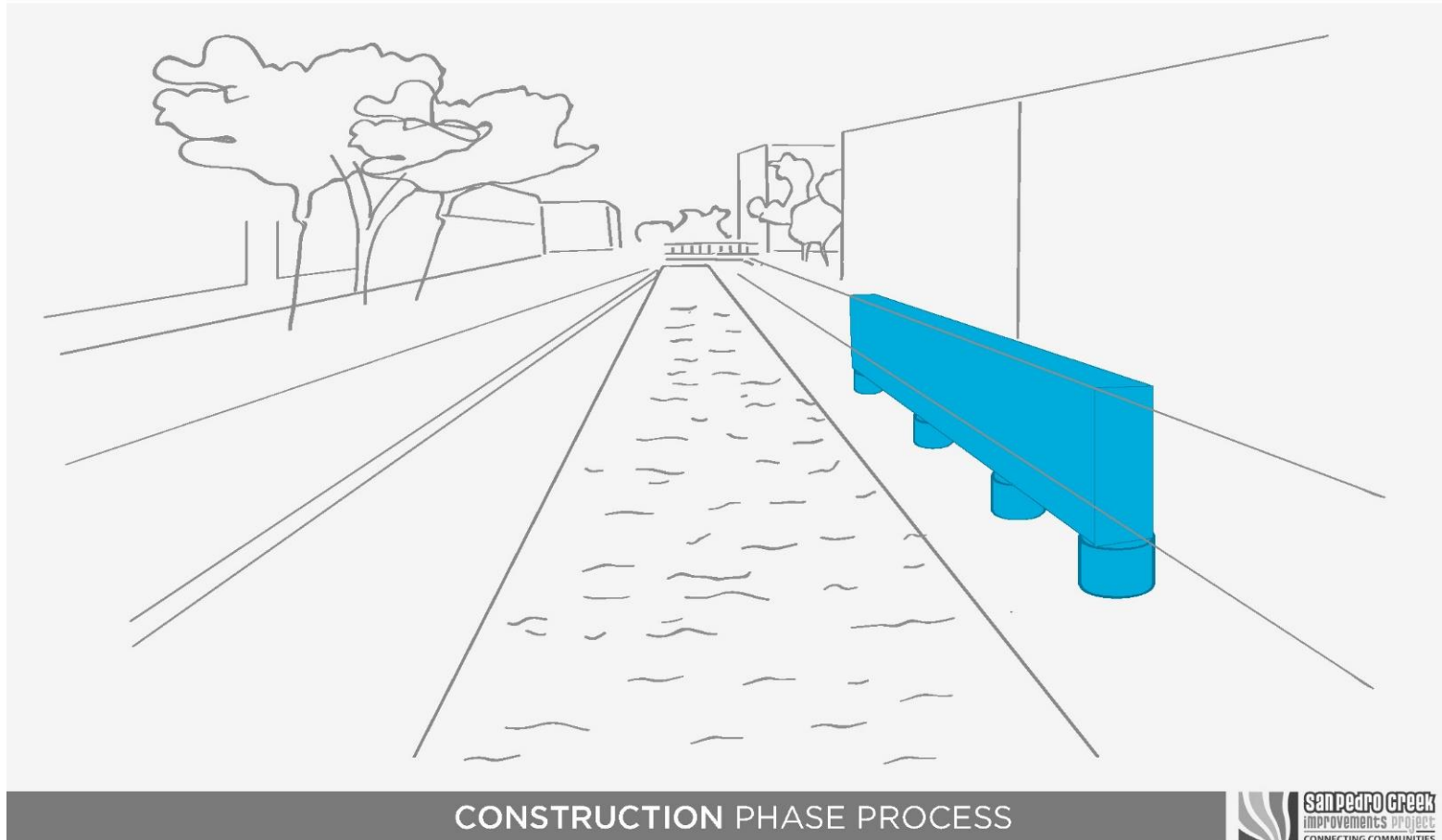

CONSTRUCTION PHASE PROCESS



Wall Stabilization
added structural supports for building wall



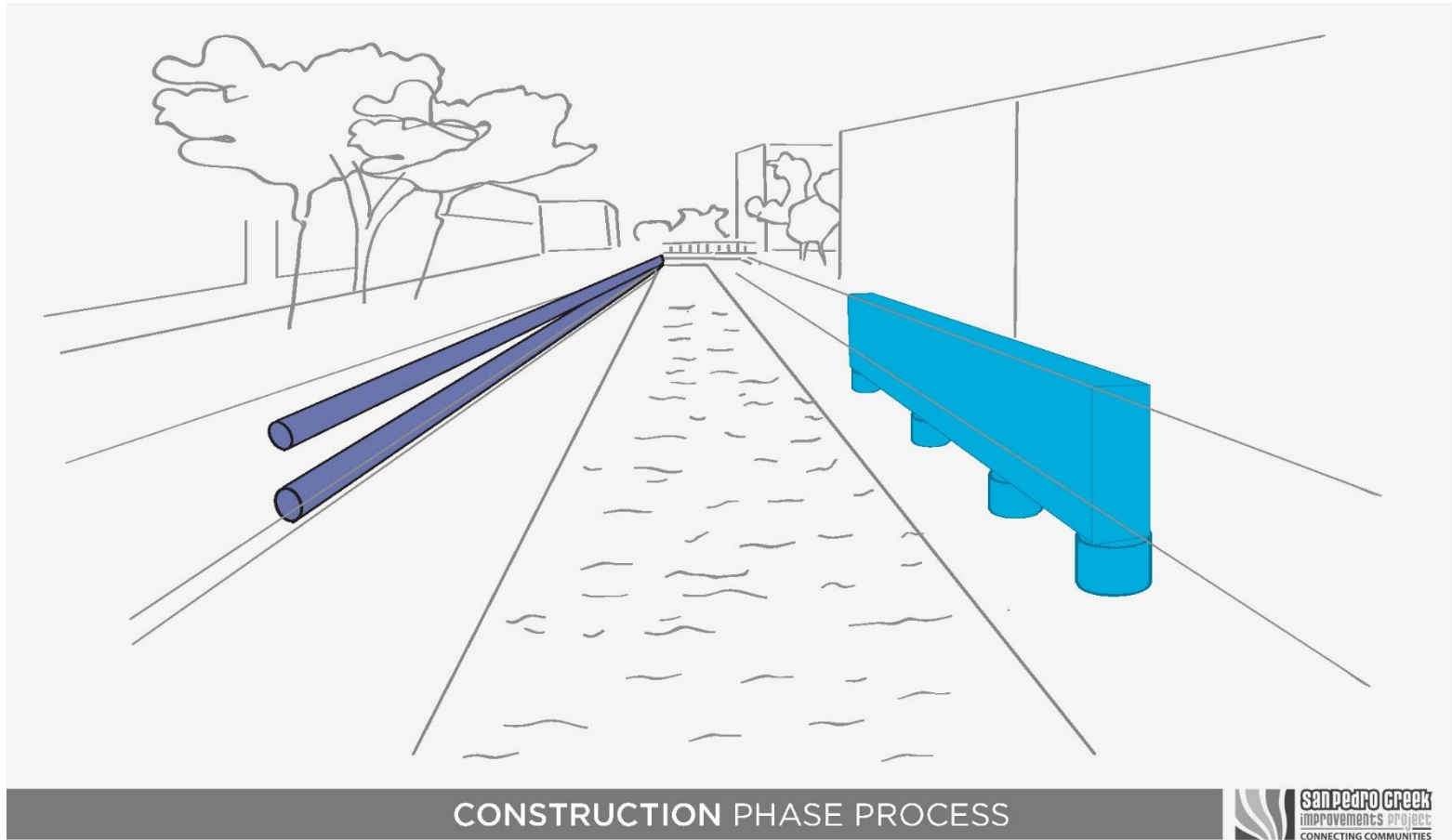

CONSTRUCTION PHASE PROCESS



Wall Stabilization
added structural supports for building wall

SAWS Utilities
moving and burying existing SAWS Utilities underneath walkway



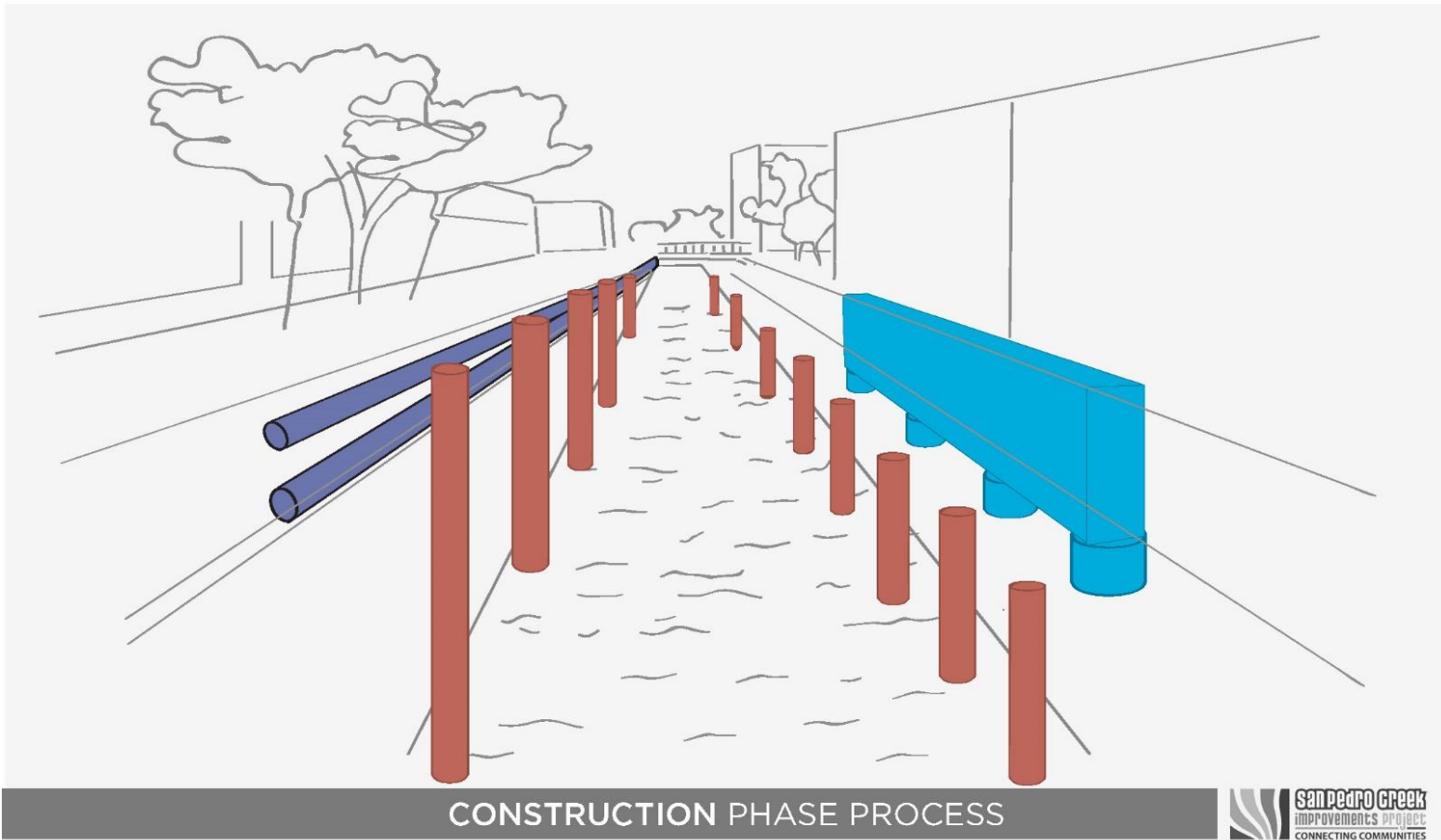

CONSTRUCTION PHASE PROCESS



Wall Stabilization
added structural supports for building wall

SAWS Utilities
moving and burying existing SAWS Utilities underneath walkway

Shafts
structural supports

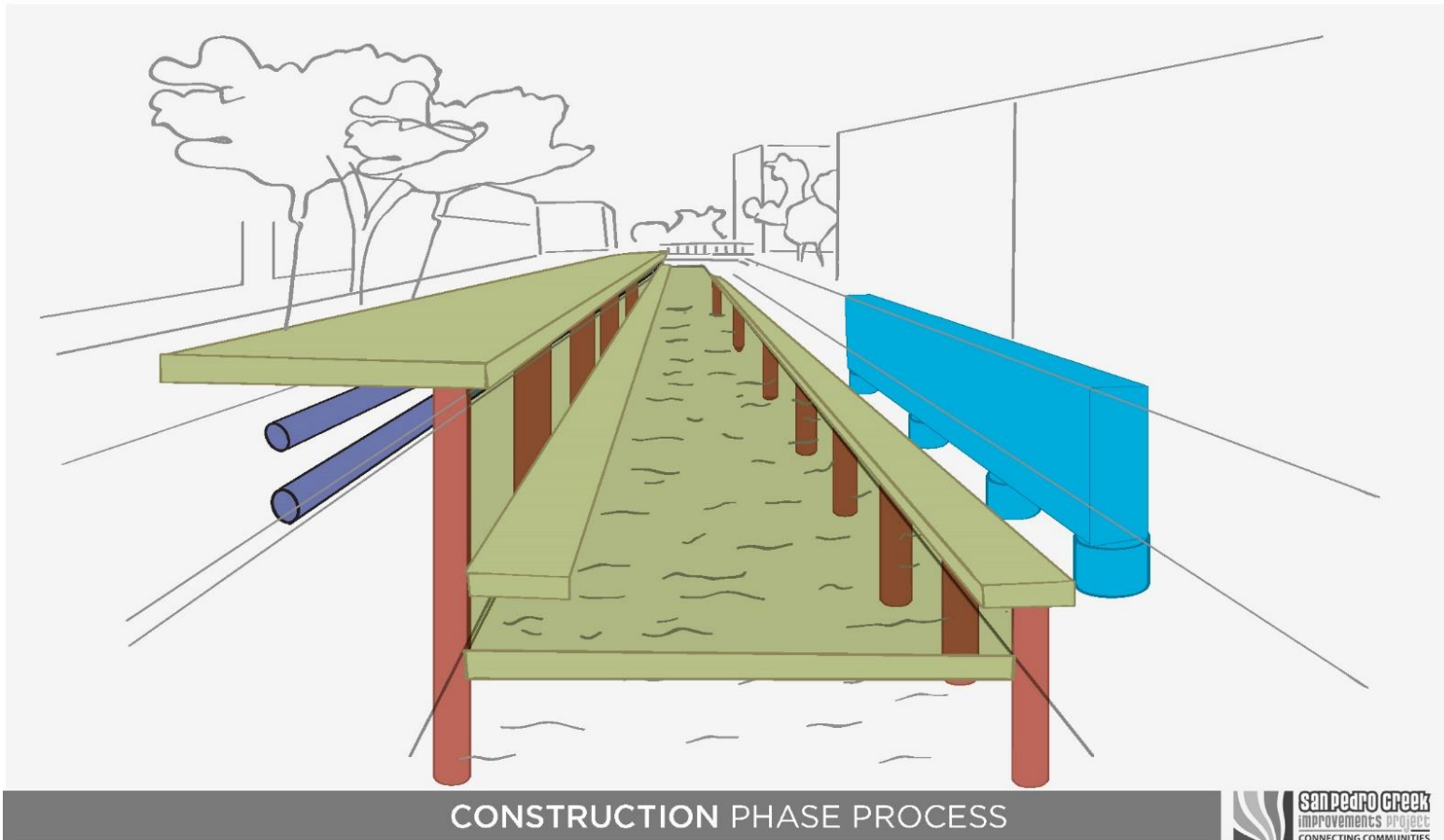

CONSTRUCTION PHASE PROCESS



- Wall Stabilization**
added structural supports for building wall
- SAWS Utilities**
moving and burying existing SAWS Utilities underneath walkway
- Shafts**
structural supports
- Remaining Structural**
lowering creek bed, new structural elements

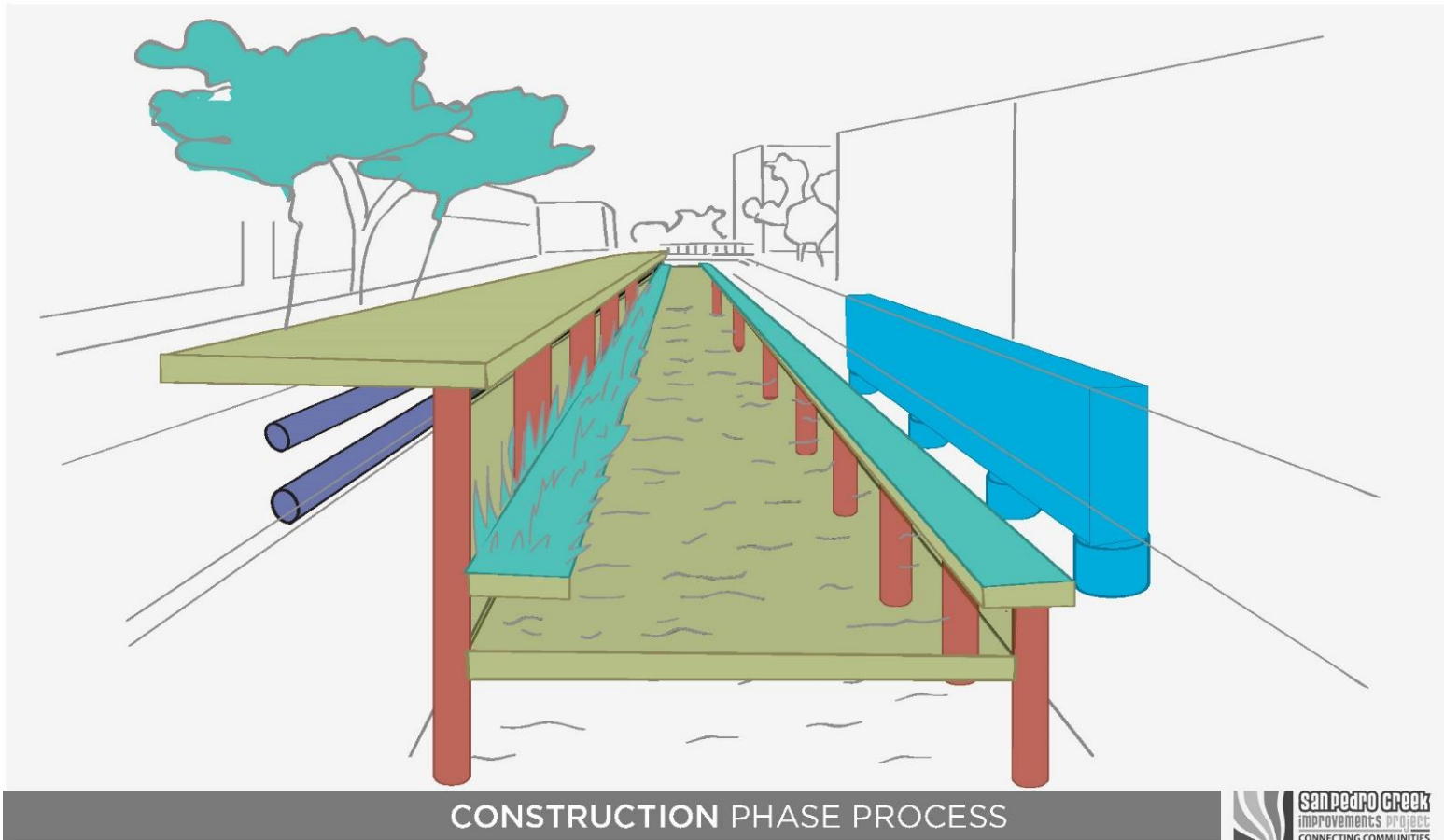

CONSTRUCTION PHASE PROCESS



Wall Stabilization
 added structural supports for building wall

SAWS Utilities
 moving and burying existing SAWS Utilities underneath walkway

Shafts
 structural supports

Remaining Structural
 lowering creek bed, new structural elements

Landscaping, Irrigation and Wayfinding
 plantings, irrigation system, paths and historical element

Construction Communication

Construction Communications

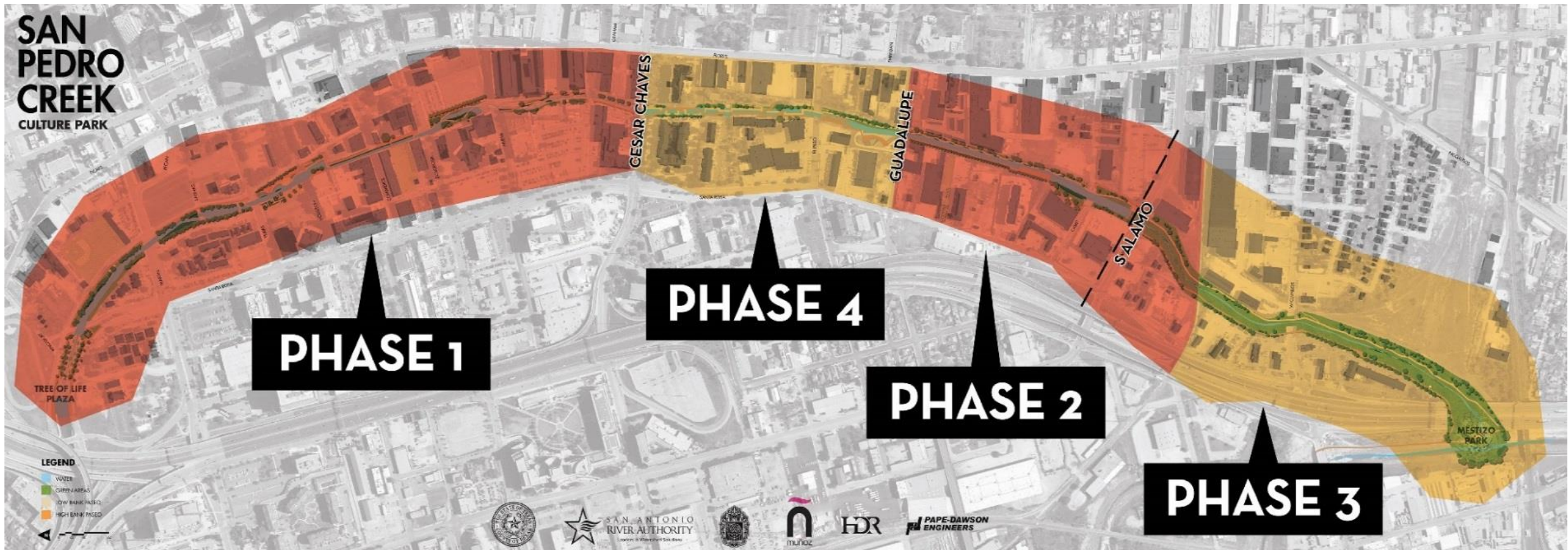

DeBerry Group and KGB Texas

Project Website Enhancements

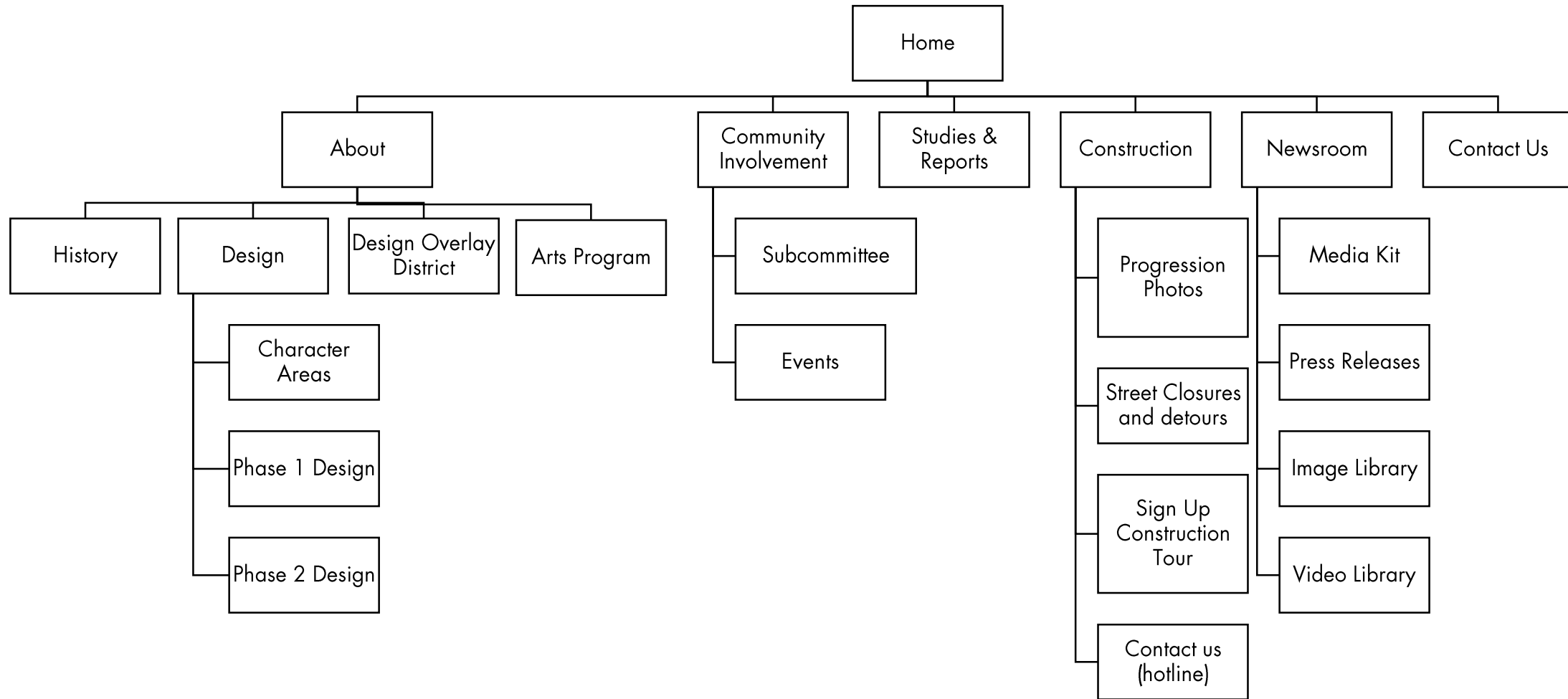

Construction Communication

- Social media
 - Facebook
 - Twitter
 - Instagram
- Phone app
- Weekly email updates
- Branding

Construction Branding

Rooted in the past,
destined for the
future.

 **san pedro creek**
improvements project
CONNECTING COMMUNITIES

www.spcproject.org



san pedro creek
improvements project
CONNECTING COMMUNITIES
WWW.SPCPROJECT.ORG

Construction Branding



www.spcproject.org

PHASE 1

COMING 2018



san pedro creek
improvements project
CONNECTING COMMUNITIES
WWW.SPCPROJECT.ORG

Construction Branding

We *flow*
with these waters
into the city created
by these springs.

 **san pedro creek**
improvements project
CONNECTING COMMUNITIES
www.spcproject.org



 **san pedro creek**
improvements project
CONNECTING COMMUNITIES
WWW.SPCPROJECT.ORG

Construction Branding

As in some
ancient legend
a city
bubbled forth.

 **san pedro creek**
improvements project
CONNECTING COMMUNITIES
www.spcproject.org



san pedro creek
improvements project
CONNECTING COMMUNITIES
WWW.SPCPROJECT.ORG

Outreach

- One-on-one meetings with property owners
- Property and business owner mixer: 11/30
- Public informational lunch: 12/15
- Presentations to associations and partner organizations

San Pedro Creek Arts

Tricentennial Artwork



Tricentennial Artwork

- Schedule

- July 8: Open Call for Artists released and advertised
- August 12: Qualifications due (112 Submittals Received)
- August 15-19: Evaluations/Reviews
- August 23: Commissioners Court approved four finalists
- October 17: Proposals due

Tricentennial Artwork

- Schedule

- October 18-25: Stakeholder/Selection committees met/Artists interviewed
- November 1: Artist and concept finalist approved by Bexar County Commissioners Court
- November: Selected artist to contract with the San Antonio River Authority for installation

Tricentennial Artwork

- Selected Artist: Jorge Rodriguez-Gerada



Tricentennial Artwork

- Selected Artist: Jorge Rodriguez-Gerada



Plethora



Plethora



San Pedro Creek
improvements Project
CONNECTING COMMUNITIES
WWW.SPCPROJECT.ORG

Plethora



Plethora



Plethora



Proposed budget

Engineering Fee	Foundation engineering and drawings	\$77,000.00
	Engineering of sculpture structure	
Design Fee	Documentation of all fabrication parts	\$38,000.00
	Fabrication protocols	
	3d modelling and geometry rationalization	
Artist Fees	Honorarium, Team and Expenses	100,000
Lighting	Gobo and other lighting	\$10,000.00
Production	Raw Material (Aluminum Sheet and Tube)	\$500,000.00
	Connection Hardware	
	Parts Assembly and Welding	
	Transportation	
	Contracting and Subcontracting Services	
	Cranes and On site equipment	
Insurance		10,000
Total		\$735,000.00



Proposed Timeline

**Design
Development**
Nov. 2016-
Jan. 2017

Assembly
July 2017-
Nov. 2017

Construction
Dec. 2017-
April 2018



**Fabrication
Tests**
Jan. 2017-
Aug. 2017

**Site
Preparation**
Sep. 2017-
Dec. 2017

Dedication
May 2018



**San Pedro Creek
Improvements Project**
CONNECTING COMMUNITIES
WWW.SPCPROJECT.ORG

San Pedro Creek Arts

- Finalizing Art Plan Program with art consultants for the long term approach to activate the Creek through the arts: rotating art, exhibitions, special events, performances.
- Interpretive Plan: stakeholder committee to review initial interpretive plan for Creek including interpretive signage, public art, and historic, artistic and cultural treatments.



SAN PEDRO CREEK

Improvements Project